

HRI
RANGE

EZi
RANGE

BBi
RANGE

HARWIN

Instruction Sheet

IS-30

Datamate L-Tek De-Latching Tool Z80-299

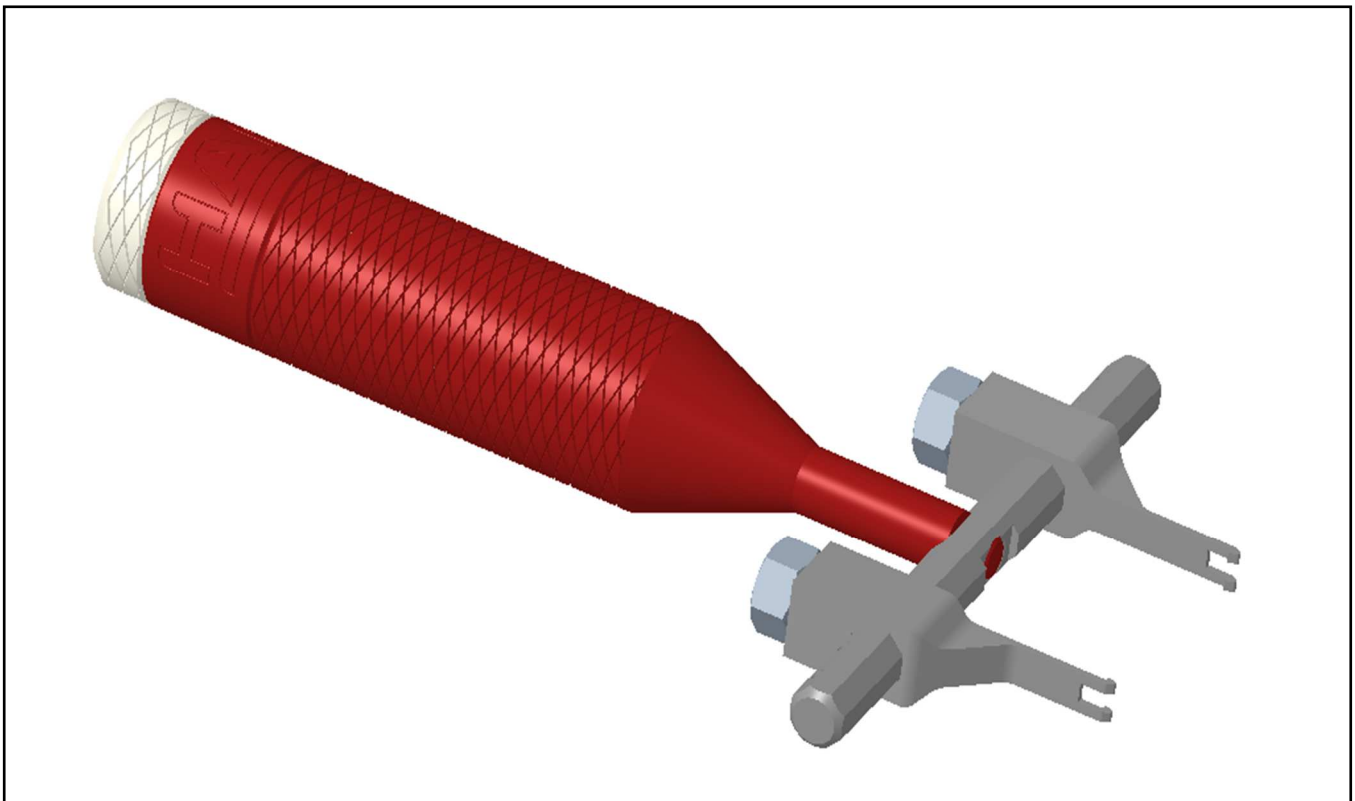



TOOL INFORMATION

This hand tool has been designed for separating mated Female/Male Datamate L-Tek assemblies where the latches are engaged and securing a pair of connectors. It is designed for use on both single row (SIL) and double row (DIL) connectors.

- DIL connectors with no. of contacts04, 06, 08, 10, 12, 14, 16, 18, 20, 26, 34, 44
- SIL connectors with no. of contacts.....02, 03, 04, 05, 06, 07, 17, 22

This tool comes supplied in a plastic storage box which contains the following items:

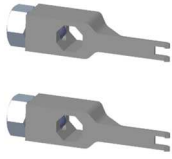
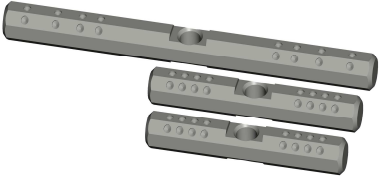
Description	Quantity	Part Number	
Handle	1	Z80-2990601	
Cap for handle	1	Z80-2990701	
Jaw assemblies (can be stored in handle)	2	Jaw Z80-2990500 Positional Screw Z80-2990800 Nut Z80-299A000	
Stainless Steel multi-position bars:			
60mm long	1	Z80-2990400	
34mm long	1	Z80-2990300	
32mm long	1	Z80-2990200	

NOTE: Part numbers are for communication reference only, and are not available as Individual Items.

ASSEMBLING TOOL

Notes:

- When assembling tool for operation, the following procedures must be observed carefully to prolong tool life and ensure damage to tool is avoided.
- When assembling parts, visually inspect threads to ensure they are clean and undamaged.
- Ensure care is taken when screwing components together to prevent cross-threading.
- Parts should only be tightened by hand, the use of spanners, levers, vices, etc. is not required, and could damage tool.
- Positional screws in adjustable jaws need not be tampered with or altered.
- If in doubt, please contact technical@harwin.com for advice and assistance.

1. Assemble the cap to the handle (if required) and the handle to the correct multi-positional bar.

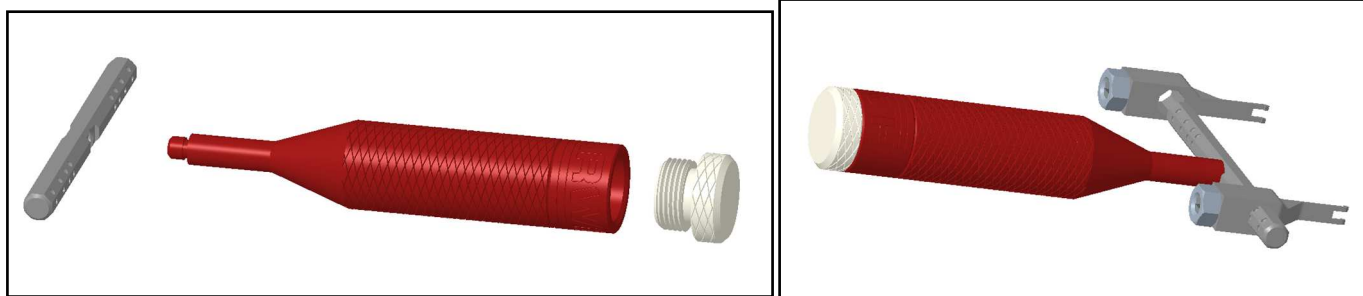

Multi-position bar size	No. of contacts	
	DIL connectors	SIL connectors
60mm long	20, 26, 34, 44	17, 22
34mm long	06, 10, 14, 18	03, 05, 07
32mm long	04, 08, 12, 16	02, 04, 06

2. Assemble adjustable Jaws by orientating the octagonal sections, then slide jaws onto bar as shown above. Alternatively, the jaws can be assembled at a 45° angle, which may be more convenient for horizontally mated connectors. The Jaws will "ratchet" along the bar and lock into various positions. Keep the jaws symmetrical about the handle; push the jaws to the correct positions for the size of the connector.



SEPARATING THE CONNECTORS

The images show the 60mm long multi-positional bar being used to separate both vertical and horizontal DIL connectors. Shown is a 20-contact connector.

- The tool is in the "Ready" position, prior to separating the connectors.

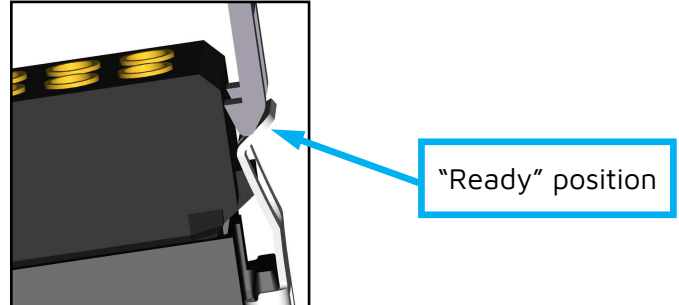

- Both jaws must be centrally positioned, resting the tool on the two latches.
- The multi-positional bar must be kept parallel to the housing, to prevent breaking the latches.
- Square cut-outs in the jaws must be aligned to clear the "Clip" feature of the latches / housings when pushed onto the connector.

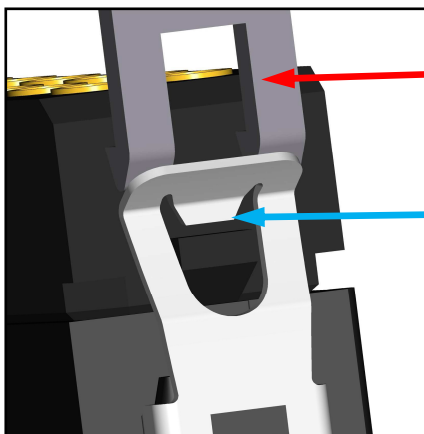
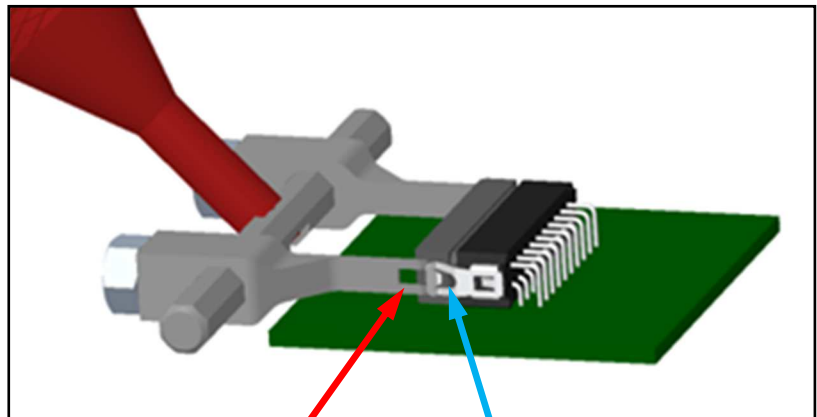
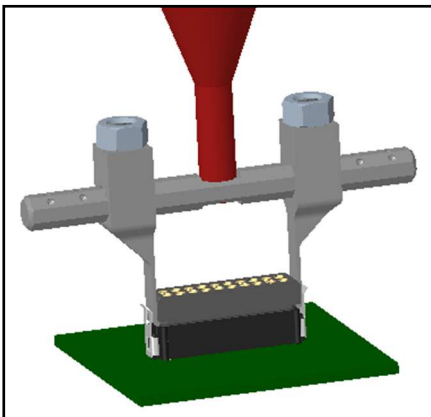

Square cut-out

"Clip" feature



- Once correctly positioned the tool can then be pushed on until the hook features of the jaws grip the female housing - see the image for how the tool should look once engaged ready to separate mated connectors.

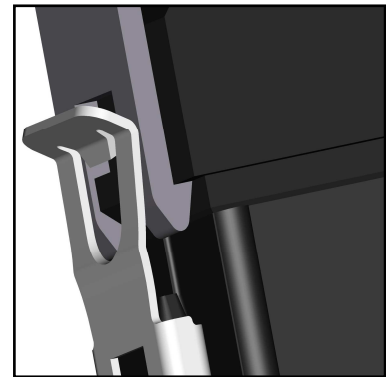

- With the de-latching tool engaged with the female housing, the connectors are now ready to be separated. Ensure a steady pulling force is applied to the tool; perpendicular to the PCB for vertical connectors and parallel to the PCB for horizontal connectors.

Keep checking that the multi-positional bar is kept parallel to the housing, to prevent breaking the latches.

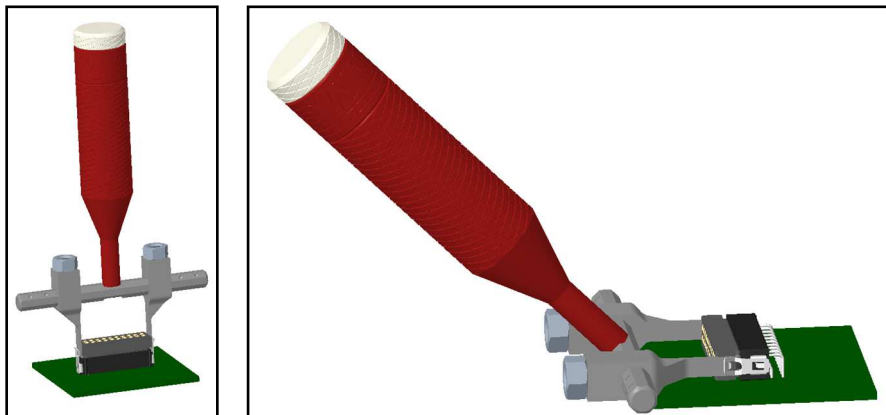

- The connectors will de-latch, and the female housing will remain between adjustable jaws of tool as shown.

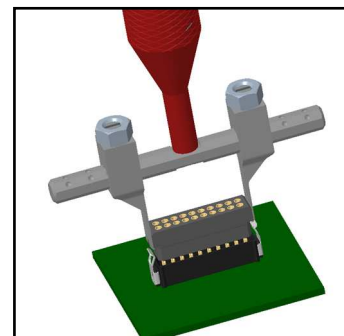

- To remove female connector from the adjustable jaws they will need to be separated by hand. Only one jaw will need to be moved to release the female connector.

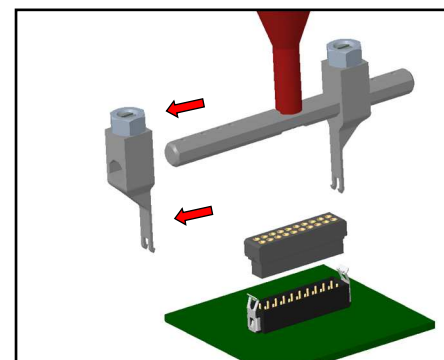



IMPORTANT NOTES

- It is strongly recommended that any latched connectors are only de-latched a maximum of 3 times. Exceeding this recommendation may result in poor retaining security between connectors.
- Connector and/or latches may require replacement if this recommendation is exceeded.
- Harwin PLC accepts no responsibility for any damages caused as a result of using this tool.
- This tool is used at your own risk.
- When the tool is not in use, it is recommended that the jaws are stored in the handle or case.
- All information in this document is to be read carefully prior to using tool. If in any doubt, please contact technical@harwin.com for advice and assistance.

