

HARWIN

Instruction Sheet

IS-01

Hand Crimp Tool M22520/2-01

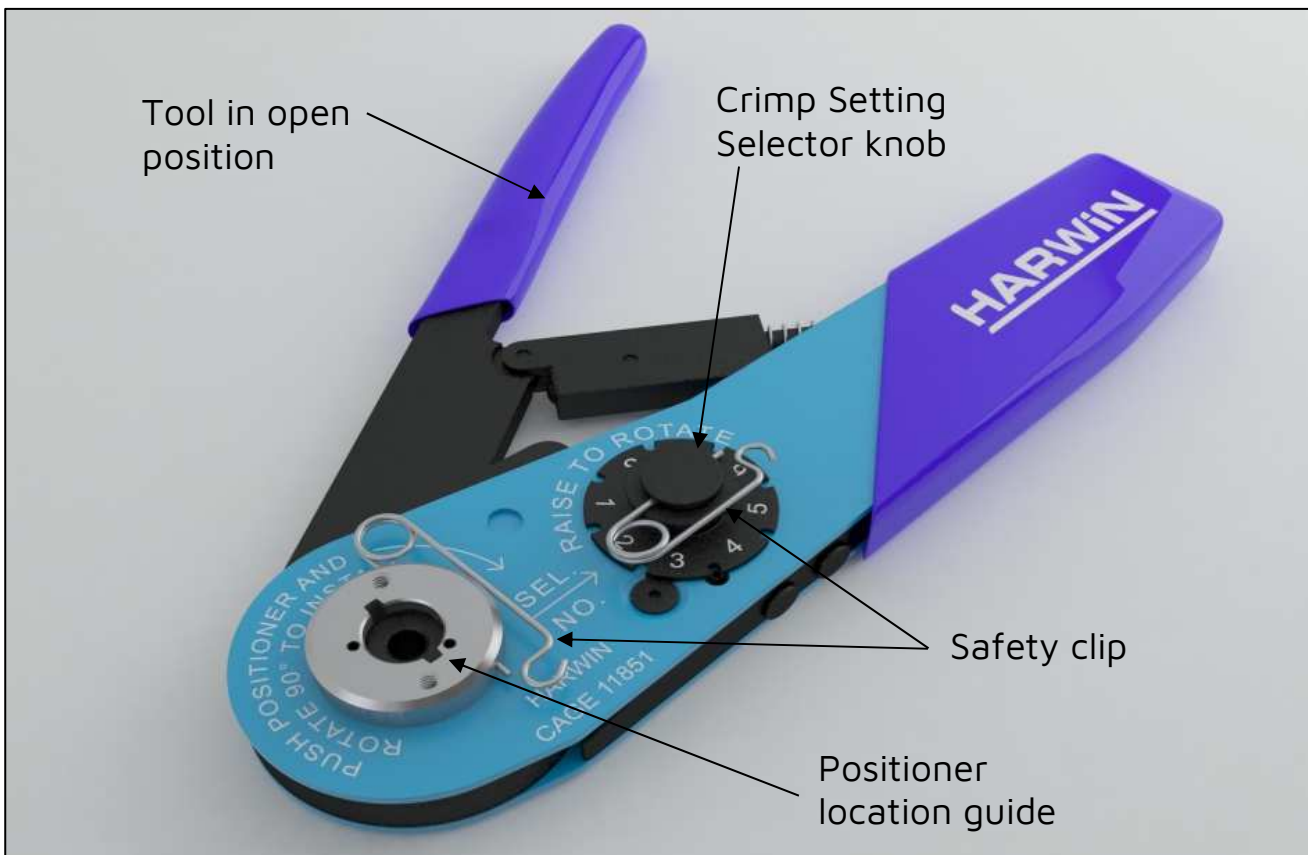



CRIMP CONTACT INFORMATION

This Hand Crimp Tool has been designed for use with the following Crimp Contacts:

Datamate Signal Crimp Sockets (use Positioner T5747):

- M80-01100XX..... Large bore Female crimp contact for 22 AWG wire
(used in all L-Tek, J-Tek and Mix-Tek female crimp connectors)
- M80-01300XX..... Small bore Female crimp contact for 24-28 AWG wire
(used in all L-Tek, J-Tek and Mix-Tek female crimp connectors)
- M80-01900XX..... Extra small bore female crimp for 28-32 AWG wire
(used in all L-Tek, J-Tek and Mix-Tek female crimp connectors)
- M83-01100XX..... Large bore Female crimp contact for 22 AWG wire
(used in 3-Row J-Tek and Mix-Tek female crimp connectors)
- M83-01300XX..... Small bore Female crimp contact for 24-28 AWG wire
(used in 3-Row J-Tek and Mix-Tek female crimp connectors)

Datamate Signal Crimp Pins (use Positioner T5747):

- M80-04000XX..... Large bore Male crimp contact for 22 AWG wire
(used in L-Tek male crimp connectors)
- M80-04100XX..... Small bore Male crimp contact for 24-28 AWG wire
(used in L-Tek male crimp connectors)

Datamate Signal Crimp Pins (use Positioner Z80-193):

- M80-19400XX..... Large bore Male crimp contact for 22 AWG wire
(used in J-Tek and Mix-Tek male crimp connectors)
- M80-19500XX..... Small bore Male crimp contact for 24-28 AWG wire
(used in J-Tek and Mix-Tek male crimp connectors)

Datamate T-Contact Crimp Contact (use Positioner Z80-444):

- M80-20600XX..... 6 Finger Datamate Female crimp contact for 22 AWG

Datamate Legacy Power and M300 Crimp Contacts (use Positioner Z80-058):

- M80-05500XX..... Power Female crimp contact for 18-20 AWG wire
(used in M80-716 and M80-719 series)
- M300-0010045..... Power Female crimp contact for 18-20 AWG wire
- M300-0020045..... Power Female crimp contact for 22 AWG wire
- M300-1010045..... Power Male crimp contact for 18-20 AWG wire
- M300-1020045..... Power Male crimp contact for 22 AWG wire



GENERAL INFORMATION

The hand crimp tool M22520/2-01 consists of a basic hand tool, which should be used with a positioner.

The contact is correctly crimped when the tool is free to open at the fully closed position, i.e., when the ratchet releases. The tool cannot be opened without completing the cycle.

TOOL PREPARATION

1. Check that the tool is in the open position. Remove the safety clip from the positioner guide (do not discard).
2. Insert the Positioner into the positioner guide and turn it 90° in the direction shown on the tool, until the bayonet pins lock.
3. Install the safety clip back into the positioner guide (optional).
4. Check Table 1 for the correct crimp tool setting of the wire size you wish to crimp.
5. Remove the safety clip from the selector knob (do not discard).
6. Lift and turn the selector knob until the correct crimp tool setting is lined up with the "Sel. No." arrow. Lower the selector knob, ensuring the locating peg lines up with a notch.
7. Install the safety clip back into the selector knob.

CRIMPING PROCEDURE

1. Ensure that the wire to be crimped is within the specified range of sizes for the contact and the crimp tool. Failure to use the specified wire size will result in poor quality crimps and possible tool damage.

| Contact | Crimp Type | Wire Gauge (AWG) | Stranding (mm) | Crimp Tool Setting | Minimum pull-off force (N) |
|--|---------------------------|------------------|----------------|--------------------|----------------------------|
| M80-01100XX M83-01100XX M80-04000XX M80-19400XX | Datamate Large Bore | 22 | 19/0.15 | 6 | 50 |
| M80-01300XX M83-01300XX M80-04100XX M80-19500XX | Datamate Small Bore | 24 | 7/0.2 | 6 | 44 |
| | | 26 | 7/0.15 | 6 | 25 |
| | | 28 | 7/0.12 | 6 | 12.5 |
| M80-01900XX | Datamate Extra Small Bore | 28 | 7/0.12 | 5 | 12.5 |
| | | 30 | 1/0.25 | 4 | 7 |
| | | 32 | 7/0.08 | 4 | 4 |
| M80-20600XX | T-Contact Large Bore | 22 | 19/0.15 | 6 | 50 |
| M80-05500XX | Datamate Power Crimp | 20 | 19/0.2 | 8 | 85 |
| | | 18 | 19/0.26 | 8 | 140 |
| M300-0010045 M300-1010045 | M300 Series Large Bore | 20 | 19/0.2 | 8 | 80 |
| | | 18 | 19/0.25 | 8 | 140 |
| M300-0020045 M300-1020045 | M300 Series Small Bore | 22 | 19/0.15 | 8 | 50 |

Table 1 - Crimp Tool Settings and Forces

2. Cut the end of the cable to be terminated so that there is a clean cut end (Figure A). Strip the cable to the correct length (Figure B). We recommend that when the wire is stripped, it is clamped or supported close to the stripping area - this will prevent insulation slippage. Suitable wire strippers (such as a PTFE wire stripper) must be used. This should result in all the strands lying together neatly. If the lay of the strands is disturbed, it may be re-imposed with a slight twist.

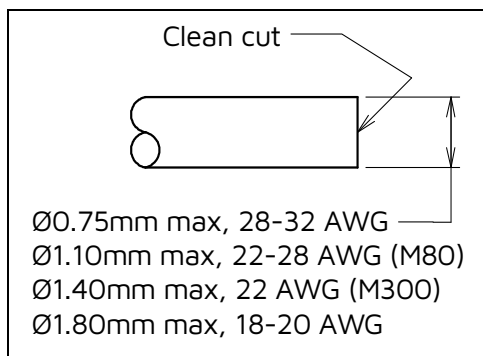

Figure A - Clean cut end

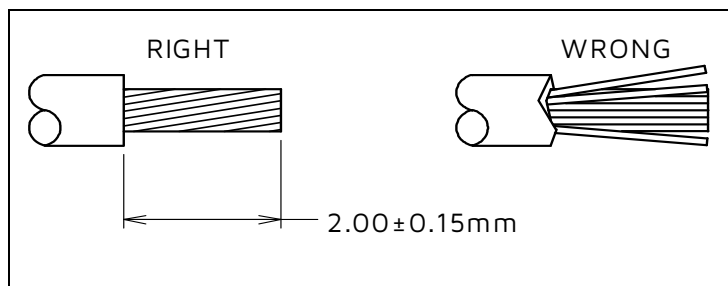

Figure B - Strip wire

3. Position the crimp contact fully into the positioner, with the crimp barrel uppermost.
4. Load the terminated end of the cable into the crimp barrel of the contact. Ensure the wire is fully inserted, with all strands in place (see Figure C).

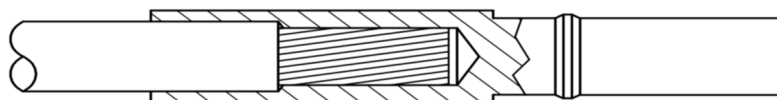

Figure C - All strands in inner crimp bore

5. Squeeze the handles of the crimp tool fully together, until ratchet releases. The handle will return to the open position. Remove the crimped contact and wire. Check that there is no exposed or stray wire, and that the insulation is fully within the end of the crimp barrel.

Note: The cross hole on the crimp barrel, although not an inspection hole (it is designed to assist with plating processes) may give approximate guidance to the location of the conductor. After crimping the contact, the indent may overlap this hole.

6. Crimp joints should be checked for:
 - a) Correct combination of cable, tool setting and crimp termination.
 - b) Correctness of form and location of crimp.
 - c) Freedom of fracture, rough edges and flash.
 - d) Adequate insertion of all conductor strands in the crimp barrel.
 - e) Absence of damage to the conductor or the insulation.



CONTACT ASSEMBLY TO HOUSING PROCEDURE

- **M80-05500XX** contactsAssembly Tool Z300-902, see [Instruction Sheet IS-40](#)
- **Other M80 Series** contacts.....Assembly Tool Z80-280, see [Instruction Sheet IS-25](#)
- **M300 Series** contacts.....Assembly Tool Z300-902, see [Instruction Sheet IS-40](#)

CARE OF TOOL

There is virtually no maintenance required for the M22520/2-01 tool. However, it is good practice to keep the indenter tips free of residual colour band deposits and other debris. A small wire brush may be used for this purpose.

We strongly recommend that you:

1. **DO NOT** immerse tools in any cleaning solution.
2. **DO NOT** spray oil into tool to lubricate.
3. **DO NOT** attempt to disassemble tool or make repairs.

This is a precision crimp tool and should be handled as such.

