

COMPONENT SPECIFICATION**025 JUMPER SOCKETS**

FEBUARY 2005

CONTENTS:

| SECTION | TITLE | PAGE |
|----------------|---|-------------|
| 1 | Description of Connector and Intended Application | 2 |
| 2 | Marking of Connector and/or Package | 2 |
| 3 | Ratings | 2 |
| Appendix 1 | Gauges | 4 |

APPENDICES NOTES:

1. Third angle projection is used where projected views are shown.
2. All dimensions are in millimetres.
3. For explanation of dimensions, etc. see BS8888.
4. Unless otherwise stated, all dimensions are maxima

PREPARED BY: APPROVED BY: AUTHORISED BY: 

| ISSUE | C/NOTE | DATE |
|--------------|---------------|-------------|
| 01 | ---- | 01.07.85 |
| 02 | ---- | 01.08.88 |
| 03 | 1567 | 01.12.89 |
| 04 | 1881 | 02.09.91 |
| 05 | 1898 | 29.10.91 |
| 06 | 2014 | 01.06.92 |
| 07 | 2283 | 18.05.93 |
| 08 | 2468 | 16.11.93 |
| 09 | 8402 | 17.02.05 |

COMPONENT SPECIFICATION

025 JUMPER SOCKETS

1. DESCRIPTION OF CONNECTOR AND INTENDED APPLICATION.

A range of 2.54mm pitch jumper sockets, consisting of a moulded outer body holding phosphor bronze spring contacts. The contacts are either tin plated overall, or selectively gold plated on the contact area. The component is intended to interconnect two adjacent 0.64mm square or round section pins on 2.54mm pitch centres. Connectors can be mounted side by side in either direction on 2.54mm pitch centres. Double and single contact versions are available, with either open or closed tops on the single row versions.

2. MARKING OF THE CONNECTOR AND/OR PACKAGE (ORDER CODE).

The marking (order code) shall appear on the package and shall be of the following style:

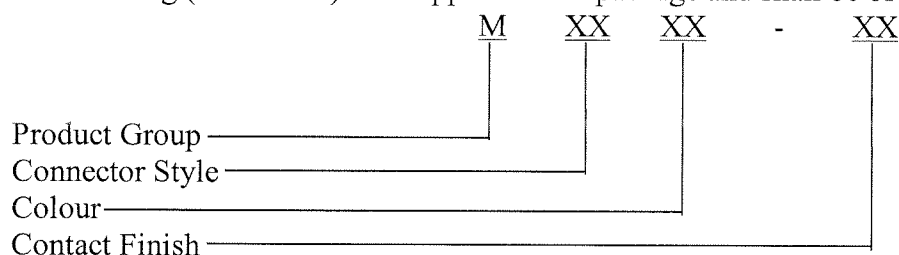

Connector Style:

| | |
|------------------------------------|----|
| Single, Open top | 75 |
| Single, Closed top | 77 |
| Single, Closed top and handle..... | 79 |
| Double..... | 85 |

Colour:

| | |
|-----------------|----|
| Light Grey..... | 65 |
| Red..... | 66 |
| Black..... | 67 |
| Blue..... | 71 |

Contact Finish:

| | |
|------------|----|
| Gold | 05 |
| Tin..... | 06 |

3. RATINGS.

3.1. ELECTRICAL CHARACTERISTICS.

| | |
|---|--|
| Current at an ambient temperature..... | 3A max |
| Working voltage | 250V DC nominal or AC peak (sea level) |
| Voltage proof | 750V rms at 50 Hz (sea level) |
| Maximum contact resistance (initially) | 20 mΩ Tin, 15 mΩ Gold |
| Maximum contact resistance (after conditioning) | 30 mΩ Tin, 25 mΩ Gold |
| Minimum insulation resistance * (initially)..... | 100,000 MΩ |
| Minimum insulation resistance * (hot after conditioning)..... | 1000 MΩ |

(* As measured between two adjacent pins not electrically connected)

COMPONENT SPECIFICATION
025 JUMPER SOCKETS (continued)

3.2. ENVIRONMENTAL CHARACTERISTICS.

Environmental classification..... 40/85/21
Low air pressure severity 300 mbar

3.3. MECHANICAL CHARACTERISTICS.

Durability 50 operations Tin, 300 operations Gold
High temperature, long term (current as in 3.1.)..... 1000 hours at 70°C
High temperature, short term (no electrical load)..... 250 hours at 85°C
Contact holding force using 100grm deadweight (using a 0.64mm square pin)
Insertion and withdrawal forces per pair: (using a 0.64mm square pin)
 Maximum insertion force 12.5N
 Minimum insertion force..... 5.0N
 Maximum withdrawal force..... 5.0N
 Minimum withdrawal force..... 1.0N

COMPONENT SPECIFICATION
025 JUMPER SOCKETS (continued)

APPENDIX 1 - GAUGES.

NOTES:

1. Material = Steel to BS1407 or equivalent.
2. Gauging surfaces to be hardened/ground to 650 H.V.5 minimum.
3. These gauges to be used for testing fully assembled components only.
4. Ultimate wear limit of 0.005mm is allowable on gauging diameters.

A1.1. ENGAGEMENT AND SEPARATION GAUGE.

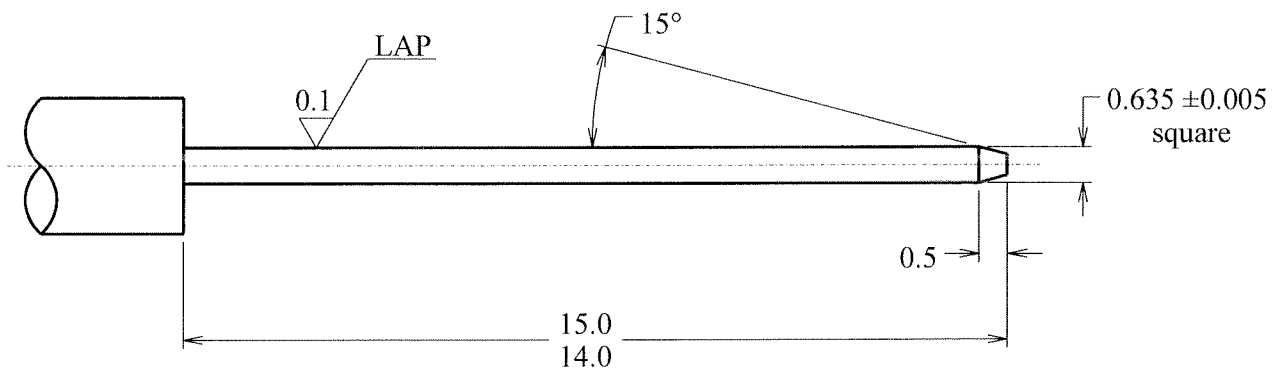

A1.2. CONTACT PUSH-OUT GAUGE.

