

Coax Contacts

Male Crimp

- ❖ 6 GHz co-axial performance.
- ❖ 50 Ohms impedance.
- ❖ Contacts are removable using extraction tool Z80-290 (see page 79).
- ❖ See page 8 for crimping instructions.

CRIMP STRAIGHT

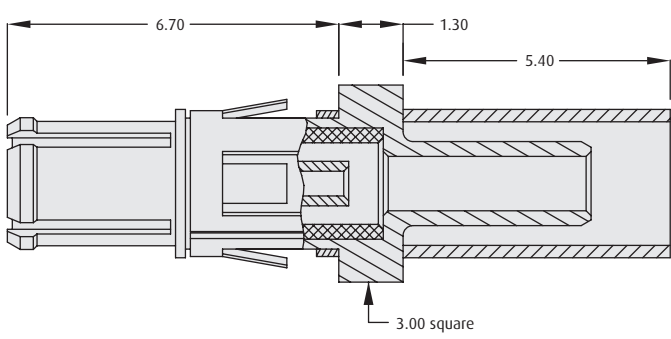

CABLE DIAMETER	ORDER CODE (LOOSE)	PART CODE (WITH ASSEMBLY)
2.0mm	M80-315	315
2.4mm	M80-316	316
2.7mm	M80-317	317

WIRE STRIPPING DETAILS

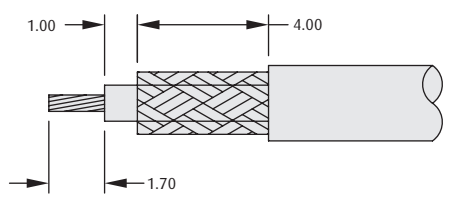

CRIMP 90°

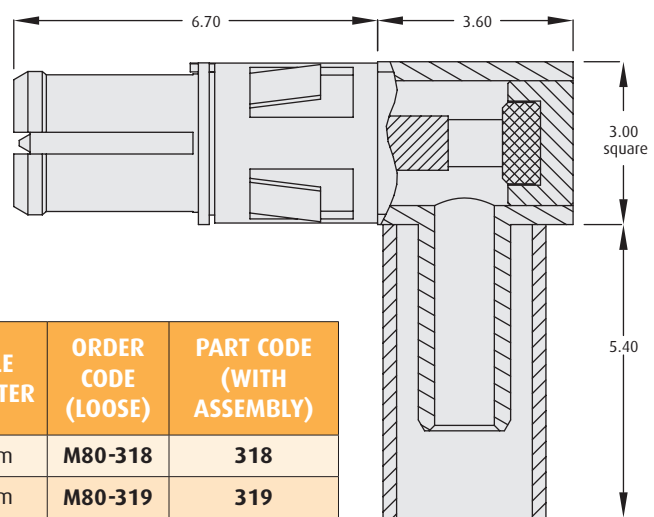

CABLE DIAMETER	ORDER CODE (LOOSE)	PART CODE (WITH ASSEMBLY)
2.0mm	M80-318	318
2.7mm	M80-319	319

WIRE STRIPPING DETAILS

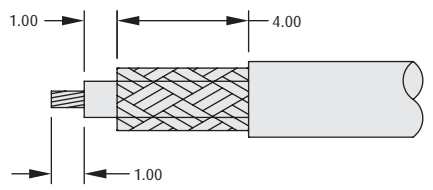

www.harwin.com

All dimensions in mm.

