

Customer Information Sheet

DRAWING No.: S2711-XXR

SHEET 2 OF 2

IF IN DOUBT - ASK

(C)

NOT TO SCALE

THIRD ANGLE PROJECTION

ALL DIMENSIONS IN mm

INCHES CONVERSIONS IN ()

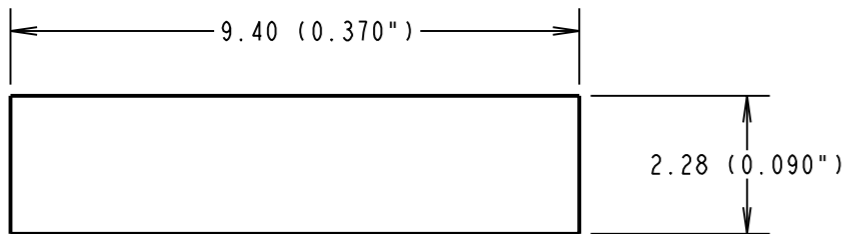
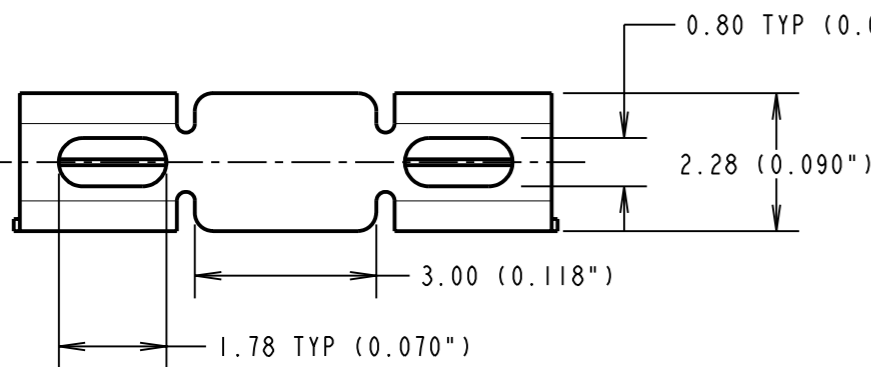
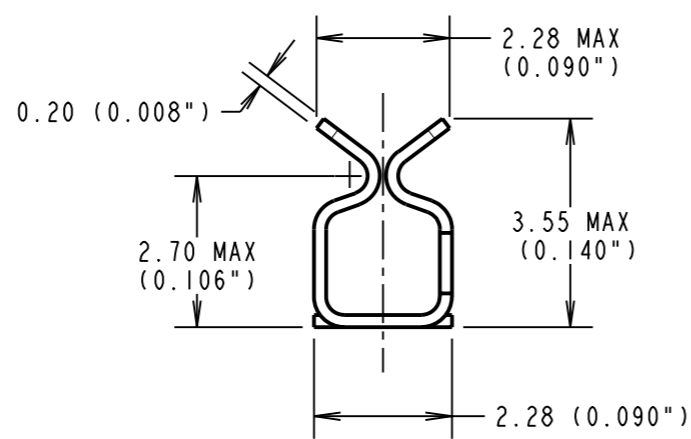
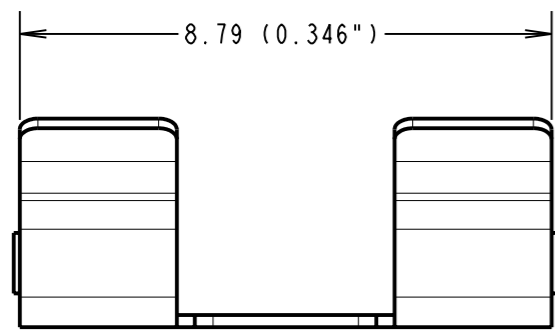

RECOMMENDED PAD LAYOUT

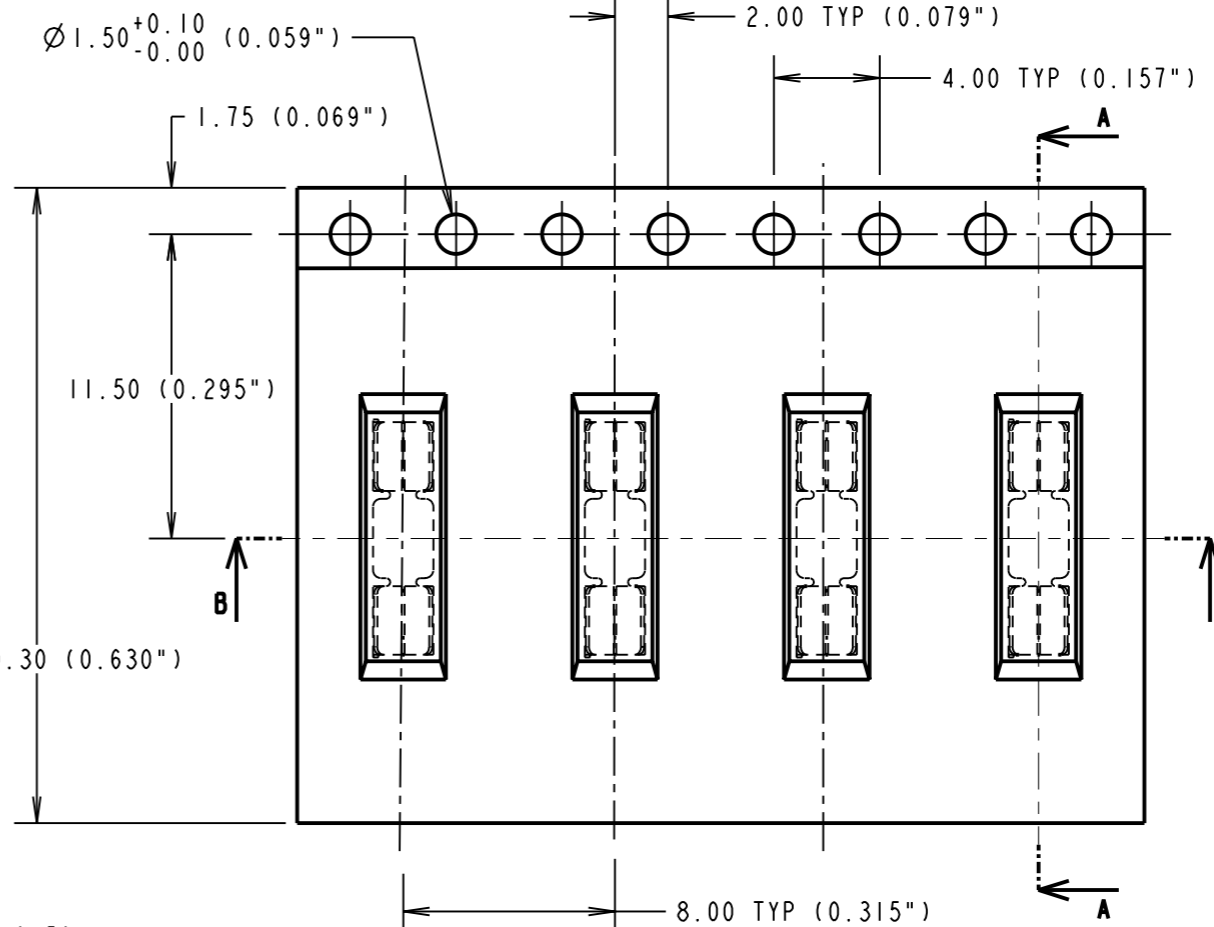
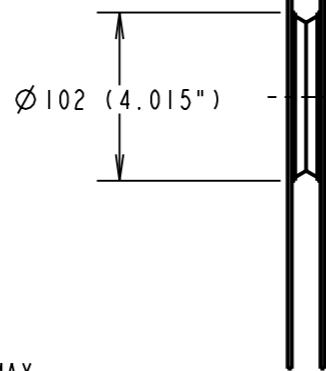

SECTION A-A

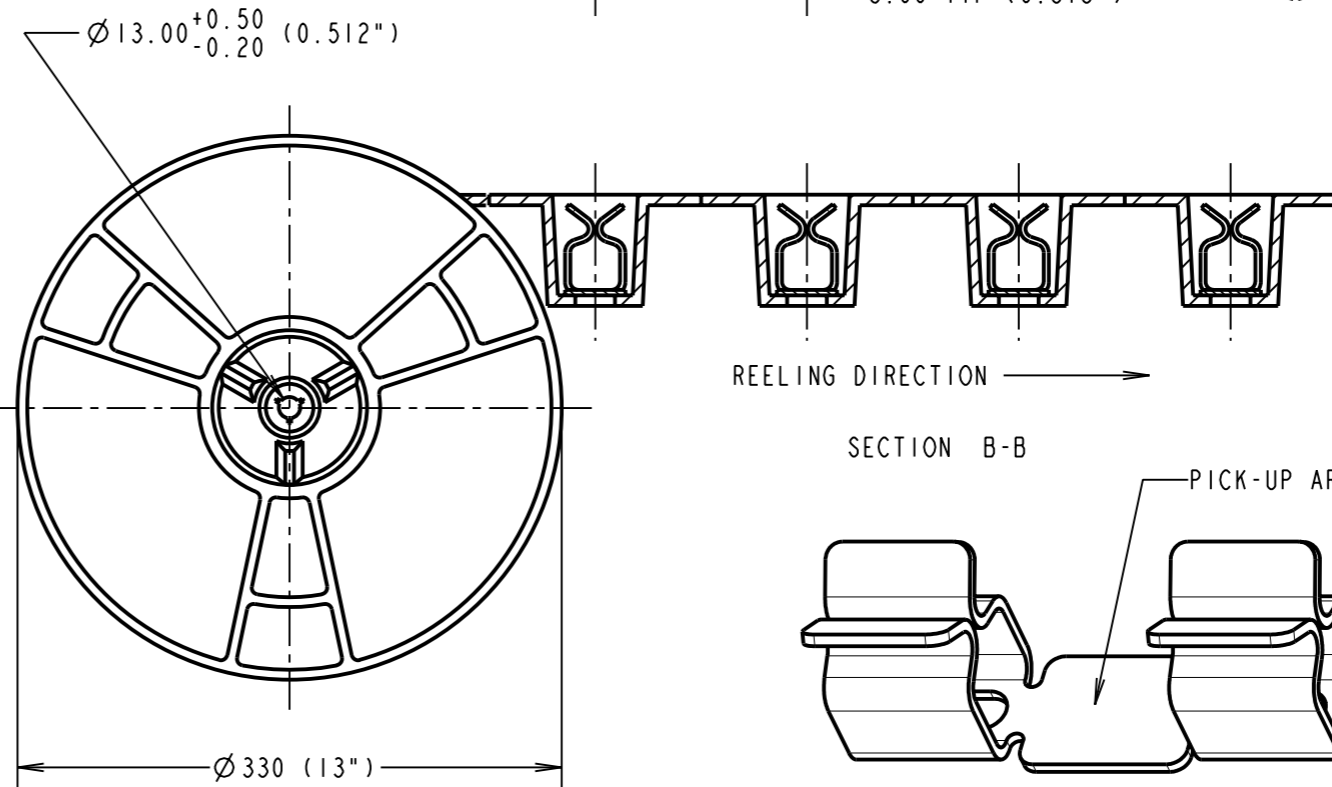
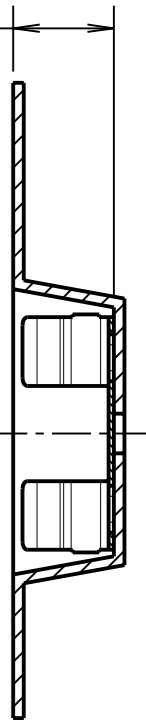

REELING DIRECTION →

SECTION B-B

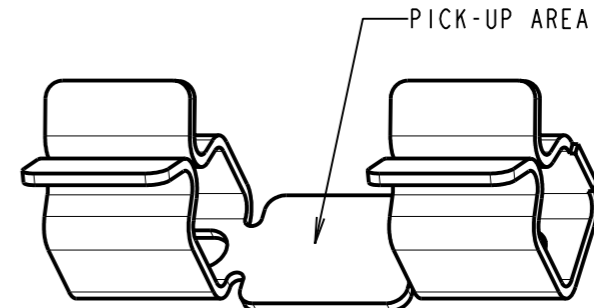

ORDER CODE:
S2711-XXR
FINISH:
06 = TIN/LEAD
46 = 100% TIN OVER NICKEL

COMPONENT SPECIFICATION:
MATERIAL = CUPRO NICKEL CuNi3SiMg
FINISH:
06 = 3µ 90/10 TIN/LEAD
46 = 3µ 100% TIN

PERFORMANCE SPECIFICATIONS:
INSERTION FORCE (AFTER CONDITIONING) = 4N MAX
WITHDRAWAL FORCE = 0.5N MIN
DURABILITY = 20 INSERTIONS MINIMUM
CONTACT RESISTANCE = 20mΩ MAX
SHIELD THICKNESS = 0.30mm ±0.02

- NOTES:
1. QUANTITY PER REEL = 1,900.
 2. THIS PRODUCT IS TAPED AND REELED IN ACCORDANCE WITH EIA-481 (ELECTRONIC INDUSTRIES ASSOCIATION).
 3. ALL SPECIFICATIONS SUBJECT TO VERIFICATION.

HARWIN

HARWIN USA TEL: 603 893 5376 FAX: 603 893 5396 mis@harwin.com	HARWIN Europe (UK) TEL: 023 9231 4545 FAX: 023 9231 4590 mis@harwin.co.uk	HARWIN Asia TEL: +65 6 779 4909 FAX: +65 6 779 3868 mis@harwin.com.sg
--	--	--

THIS DRAWING AND ANY INFORMATION OR DESCRIPTIVE MATTER SET OUT HEREON ARE CONFIDENTIAL AND COPYRIGHT PROPERTY OF THE HARWIN GROUP AND MUST NOT BE DISCLOSED, LOANED, COPIED OR USED FOR MANUFACTURING, TENDERING OR FOR ANY OTHER PURPOSE WITHOUT THEIR WRITTEN PERMISSION.

TOLERANCES
X. = ±1mm
X.X = ±0.25mm
X.XX = ±0.10mm
X.XXX = ±0.01mm
ANGLES = ±5°
UNLESS STATED

MATERIAL: SEE ABOVE
FINISH: SEE ABOVE
S/AREA: mm²

TITLE: SMT RFI SHIELD CLIP IN TAPE AND REEL (CUPRO NICKEL)

DRAWING NUMBER: **S2711-XXR**

SHT 2 OF 2

CP	4	25.06.10	10850
NAME	ISS.	DATE	C/NOTE
APPROVED: C.PENROSE			
CHECKED: R.ADDE			
DRAWN: J. EVANS			
CUSTOMER REF.:			
ASSEMBLY DRG:			