

# Customer Information Sheet

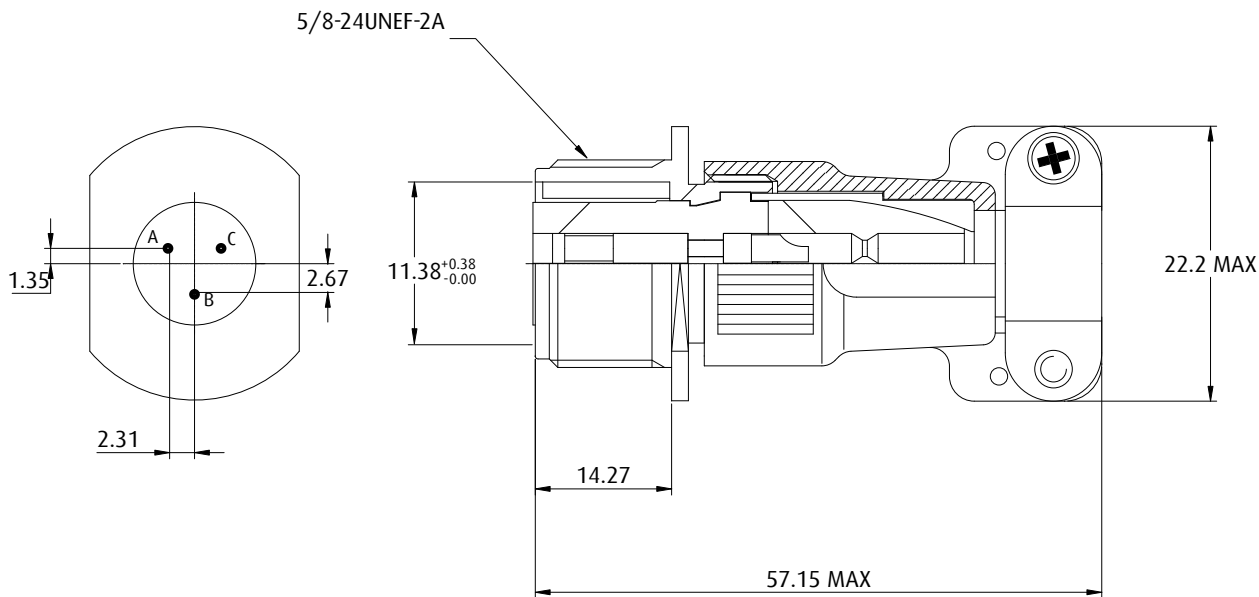

## Specification

### Materials & Finishes

Shell : aluminum alloy, zinc plated with black chromate  
Coating  
Insulator : Polychloroprene  
Grommet : polychloroprene  
Contact : Copper alloy, Silver plated

### Mechanical Features

Coupling : Threaded  
Polarisation : single key/keyway  
Contact type : Solder  
Contact Arrangement : 3 Contacts  
Durability : 500 cycles, mate and unmate

### Electrical Data

Current Rating : 13 amps  
Voltage Rating : Working 500V(AC), 700V(DC)  
Insulation Resistance : 5,000 Mega Ohms Min

### Environmental Data

Operating Temperature : -55°C to +125°C  
Vibration : 10 ~ 500Hz(10G), per MIL-STD-1344, method 2005  
Salt Spray : 48hrs. Salt solution 5%, per MIL-1344,  
method 1001  
Humidity : Relative Humidity 95±3%, 71°C±2°C, 14days