

Datamate Connectors

Male Crimp Reverse Fix

- ❖ Mates with female connectors shown on pages 29 and 32.
- ❖ Allows for further flexibility in system design.
- ❖ Crimp contacts supplied loose.
- ❖ Crimp contacts are rear insertable and replaceable.
- ❖ Large bore 22 AWG, small bore 24 – 28 AWG.
- ❖ Part numbers are for housings and the equivalent number of contacts.

WITH JACKSCREWS

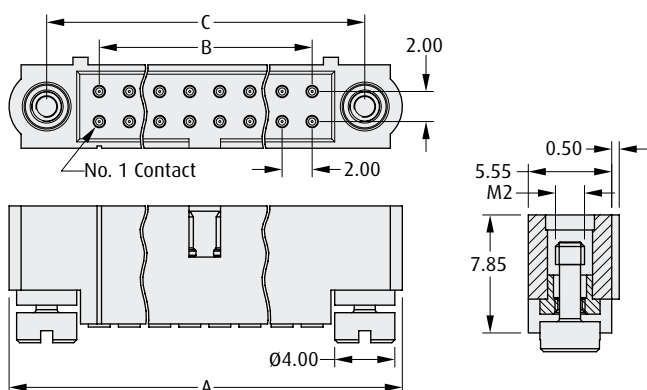

CALCULATION

A	B + 12
B	Total No. of contacts - 2
C	B + 7

CRIMP CONTACTS

Large Bore (22 AWG):

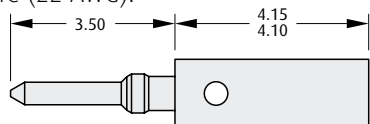

Small Bore (24-28 AWG):

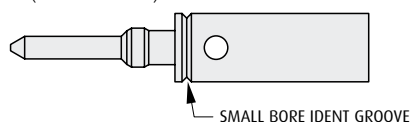

TOOLS

Recommended Crimp Tool - M22520/2-01

Positioner - Z80-193

Contact Insertion/Removal Tool - Z80-280

See pages 61 to 62

❖ Instruction sheets available at www.harwin.com/Downloads/Instructions

WIRE STRIPPING DETAILS

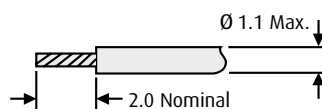

HOW TO ORDER

M80 - XXX XX 05

SERIES CODE

TYPE	
194	Large Bore Contact
195	Small Bore Contact
562	Large Bore Connector
563	Small Bore Connector

FINISH

05	Gold	
-----------	------	--

TOTAL NO. OF CONTACTS

Connector	06, 10, 12, 14, 20, 26, 34, 42, 50
Contacts	00

www.harwin.com

All dimensions in mm.

